

Programmable transmitter of CO₂ concentration

T5340, T5341, T5440, T5441

**Programmable transmitter of temperature, relative humidity,
CO₂ and other derived humidity values**

T6340, T6341, T6440, T6441

with RS232 / RS485 serial output

Instruction Manual

Instruction Manual

The transmitters are designed for online measurement of temperature (°C or °F), relative humidity and carbon dioxide concentration of air without aggressive ingredients. Measured temperature and relative humidity are recomputed to following humidity expression: dew point temperature, absolute humidity, specific humidity, mixing ratio and specific enthalpy.

Device type	Temperature	Humidity	CO ₂	Computed values	Output	Galvanic isolated output
T5340	-	-	✓	-	RS232	-
T5341	-	-	✓	-	RS232	-
T5440	-	-	✓	-	RS485	✓
T5441	-	-	✓	-	RS485	✓
T6340	✓	✓	✓	✓	RS232	-
T6341	✓	✓	✓	✓	RS232	-
T6440	✓	✓	✓	✓	RS485	✓
T6441	✓	✓	✓	✓	RS485	✓

A multiple point CO₂ and temperature adjustment procedure leads to excellent CO₂ measurement accuracy over the entire temperature working range; this is a must for process control and outdoor applications. The dual wavelength NDIR CO₂ sensing procedure compensates automatically for ageing effects. The CO₂ module is highly resistant to pollution and offers maintenance free operation and outstanding long term stability. Measured values can be read in „SLOW mode“ (filtered, averaged) or in „FAST mode“ (current values without averaging). SLOW mode has advantages in applications like climate control because of filtering short time peaks. As an example exhaled air from an employee passing the sensor could affect the climate control negatively with a short response time because the control would trigger a change of the ventilation based on this one-time measurement. On the contrary in „FAST mode“ no software filter is used for calculating the output value. This fact adds a noise of typ. ±30ppm which has to be considered in terms of accuracy. Of principle measurement is the measured value of CO₂ concentration depends on the value of air pressure - altitude at the installation site. For this reason, it is suitable for accurate measurement to set the altitude of the installation site by TSensor software.

Measured values are displayed on dual line LCD display. The visual indication of CO₂ concentration is provided by three-color LED.

After power up of the device starts internal test. During this time (about 20s) LCD display shows (----) instead of CO₂ concentration value.

Devices T5340, T5341, T6340 and T6341 communicate via link RS232, devices T5440, T5441, T6440 and T6441 via link RS485. Supported communication protocols are Modbus RTU, protocol compatible with standard Advantech-ADAM, ARION and communication with HWg–Poseidon devices (the reading of CO₂ concentration is not supported by ARION and HWg-Poseidon protocols). Devices are preset from manufacturer to Modbus RTU communication protocol. Measured and computed values are optionally shown on dual line LCD display. If there are two values displayed at one LCD line, they are periodically switched between both readings with period of 4 seconds. Display can be switched OFF totally too.

Use user's software *Tsensor* for setting of all device parameters (recommended) including conditions of CO₂ concentration measurement. It is free to download at www.cometsystem.com. It supports make the adjustment of the device too. This procedure is described at file „*Calibration manual.pdf*“ which is installed commonly with the software. Change of some parameters is possible to do without user's software with Windows hyperterminal (change of communication protocol, its

parameters, LCD display setting). It is described in file “*Description of communication protocols of Txxxx series*” which is free to download at the same address.

Transmitter version TxxxxL with male Lumberg RSFM4 connector instead of a cable glands is designed for easy connection/disconnection of communication cable.

Models marked TxxxxZ are non-standard versions of the transmitters. Description is not included in this manual.

Please read instruction manual before the first device connection.

Device setting from the manufacturer

If special setting was not required in the order device is set from the manufacturer to the following parameters:

communication protocol:	Modbus RTU
device address:	01
communication speed:	9600Bd, without parity, 2 stop bits
display:	switched ON
value displayed at higher line:	CO ₂ , temperature/CO ₂ – by device type
value displayed at lower line:	relative humidity
temperature unit:	°C
preset computed value:	dew point temperature
measurement mode:	SLOW
display:	switched ON
LED indication:	up to 1000 ppm lights green LED, between 1000 and 1200 ppm lights yellow LED and over 1200 ppm lights red LED
altitude:	300 m above sea level at the installation site

Modification of the setting is possible to do by means of the PC and TSensor program.

Device installation

Device is designed for wall mounting. There are two mounting holes at the sides of the case. Unpack the external CO₂ probe (T5341, T5441, T6341 and T6441) and connect it to the device. Then place the probe into the measured environment. Interconnection terminal (devices T534x, T544x, T634x and T644x) is accessible after unscrewing four screws and removing the lid. Pass the cables through a released glands and connect the wires according to diagram. Do not forget to tighten glands and screw the lid. Connect complementary female connector for T534xL, T544xL, T634xL and T644xL transmitters in accordance with the table in Appendix B of this manual. Don't connect transmitter while power supply voltage is on. The working position of T5340(L) and T5440(L) transmitters is with cable glands (connector) upwards, the working position of T6340(L) and T6440(L) is with sensor cover downwards and transmitters T5341(L), T5441(L), T6341(L), T6441(L) are installed in any position.

It is not recommended to use the devices T6340(L), T6440(L) and external RH+T probe of T6341(L), T6441(L) transmitters for long time under condensation conditions. It could be the cause of water steam condensation inside the sensor's cover into water phase. This liquid phase stays inside sensor's cover and can't escape from the cover easily. It can dramatically increase response time to relative humidity change. If water condensation occurs for longer time it can cause sensor damage. Similar effect can occur under water aerosol conditions.

Devices T534x and T634x are supplied with connection cable equipped with connector for connection to RS232 interface.

For devices T544x and T644x with RS485 output there is recommended to use shielded twisted copper cable, maximal length 1200m. The cable must be located at indoor rooms. Nominal cable impedance should be 100 Ω, loop resistance max. 240 Ω, cable capacity max. 65 pF/m. Outside diameter of the cable for device connection must be from 3 to 6.5 mm. Suitable cable is e.g. SYKFY 2x2x0.5 mm², where one wire pair serves for device powering and the other pair for communication link. The cable should be led in one line, i.e. NOT to „tree“ or „star“. Termination resistor should be located at the end. For short distance other topology is allowed. Terminate the network by a termination resistor. The value of the resistor is recommended about 120 Ω. For short distance termination resistor can be left out.

For T534xL, T544xL, T634xL, T644xL transmitters connection use cable with respect to female connector parameters. Do NOT connect shielding at connector side.

The cables should not be led in parallel along power cabling. Safety distance is up to 0.5 m, otherwise undesirable induction of interference signals can appear.

Electrical system (wiring) may do only worker with required qualification by rules in operation.

Dimensions

T5340, T5440

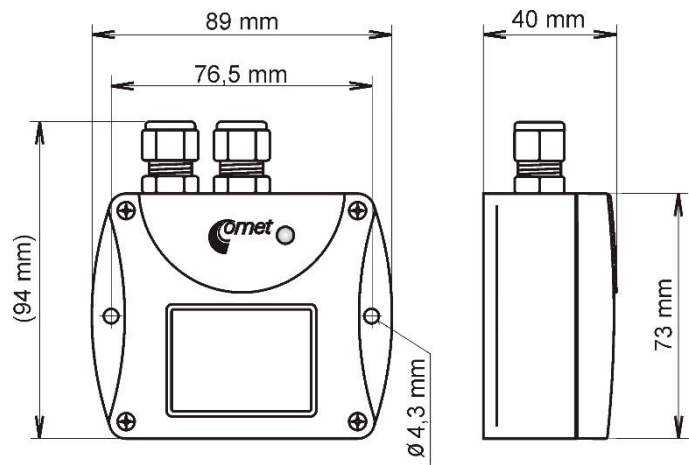

T5340L, T5440L

Connection:
see Appendix B

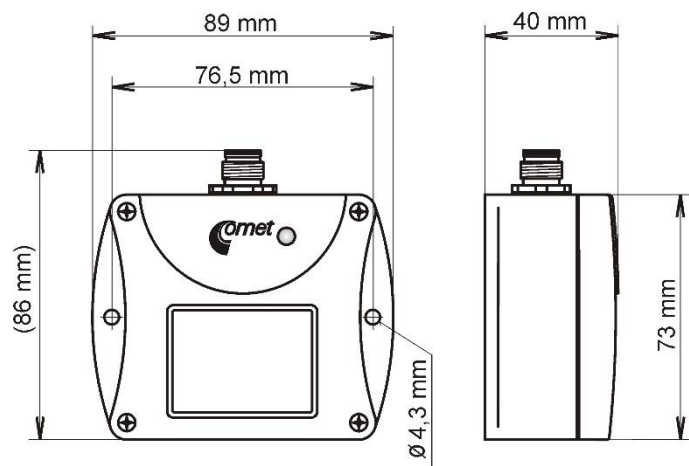

T5341, T5441

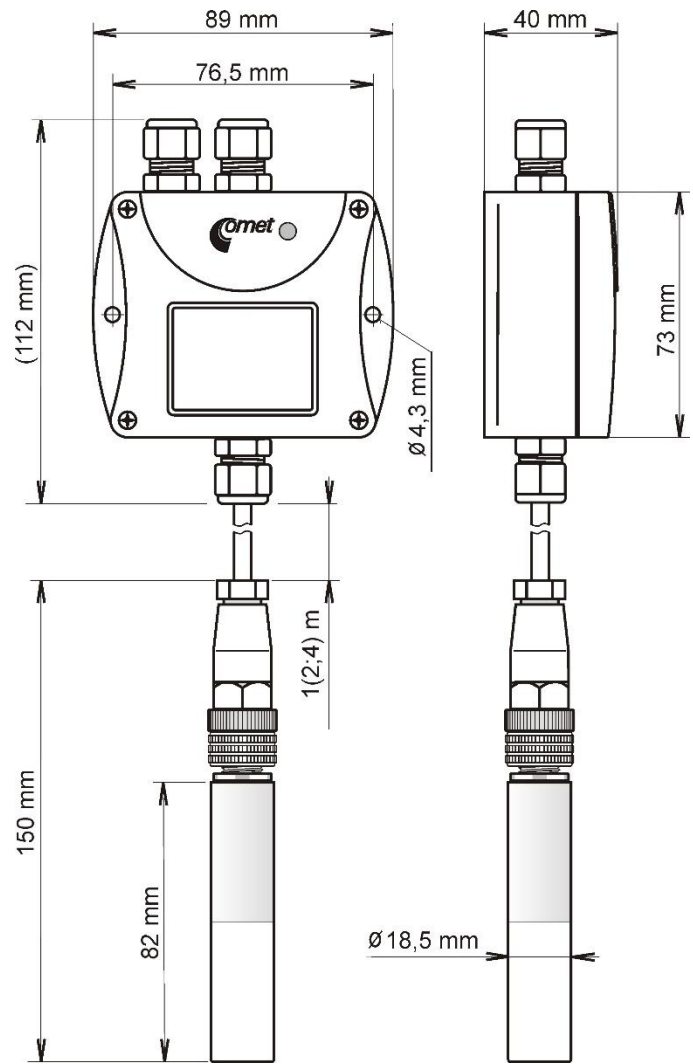

T6340, T6440

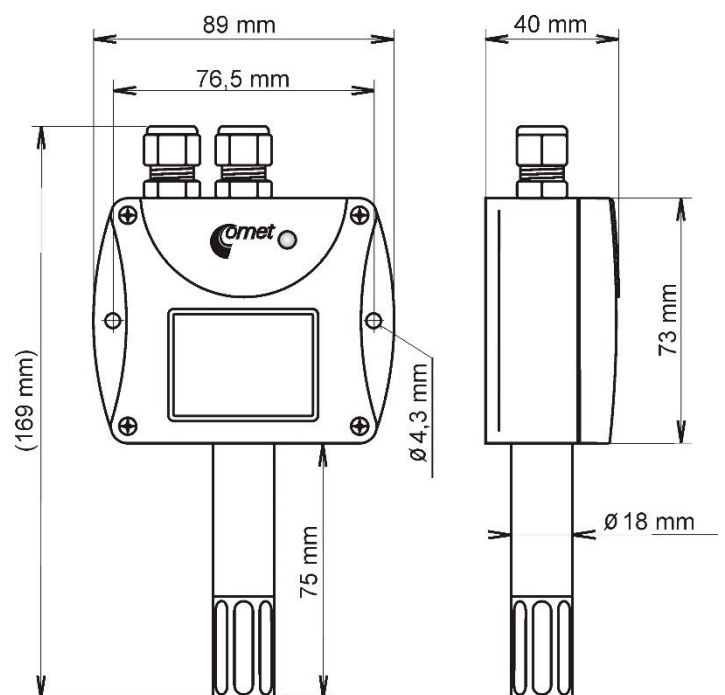

T5341L, T5441L

Connection:
see Appendix B

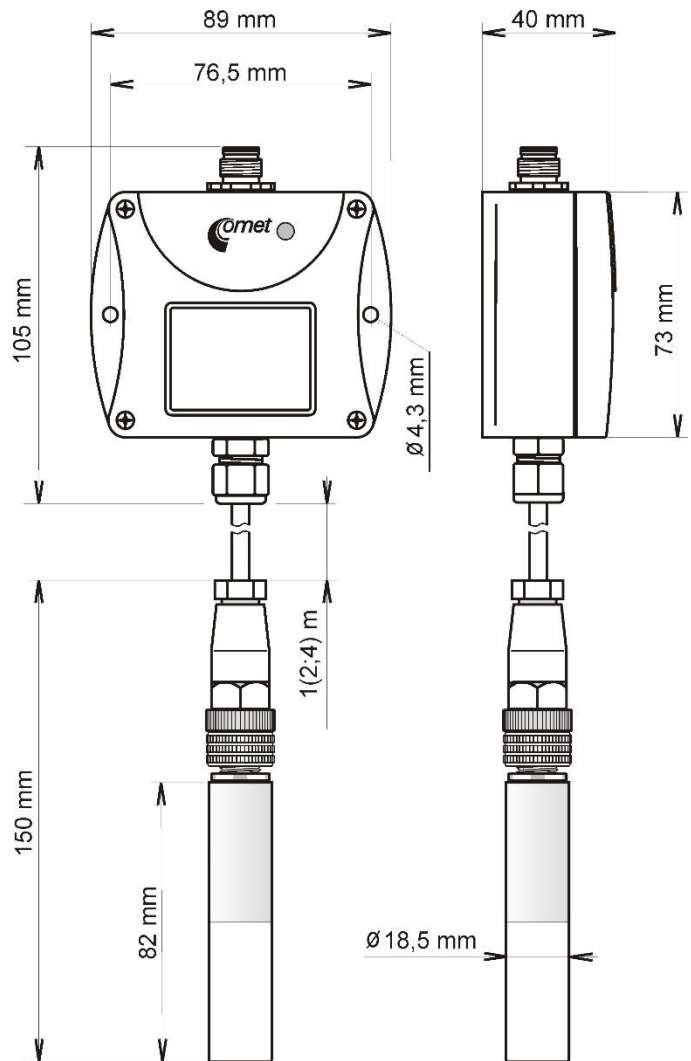

T6340L, T6440L

Connection:
see Appendix B

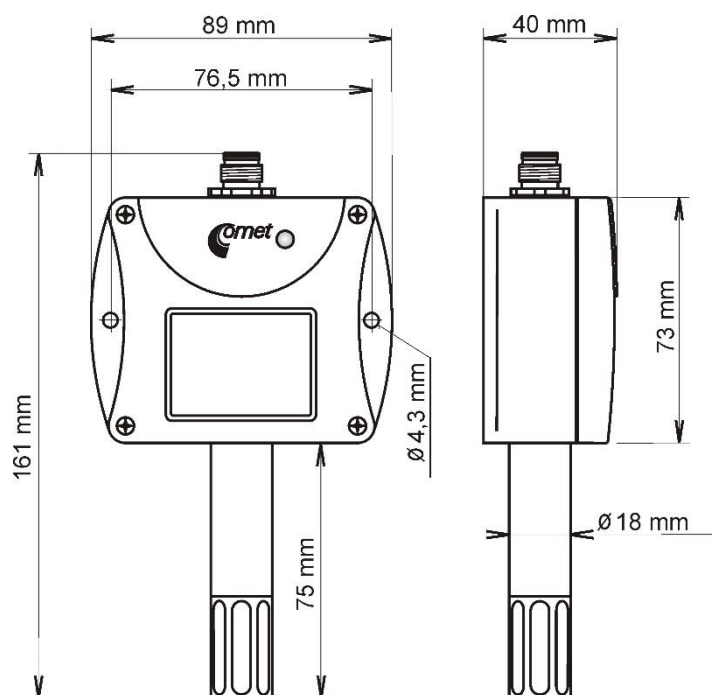

T6341, T6441

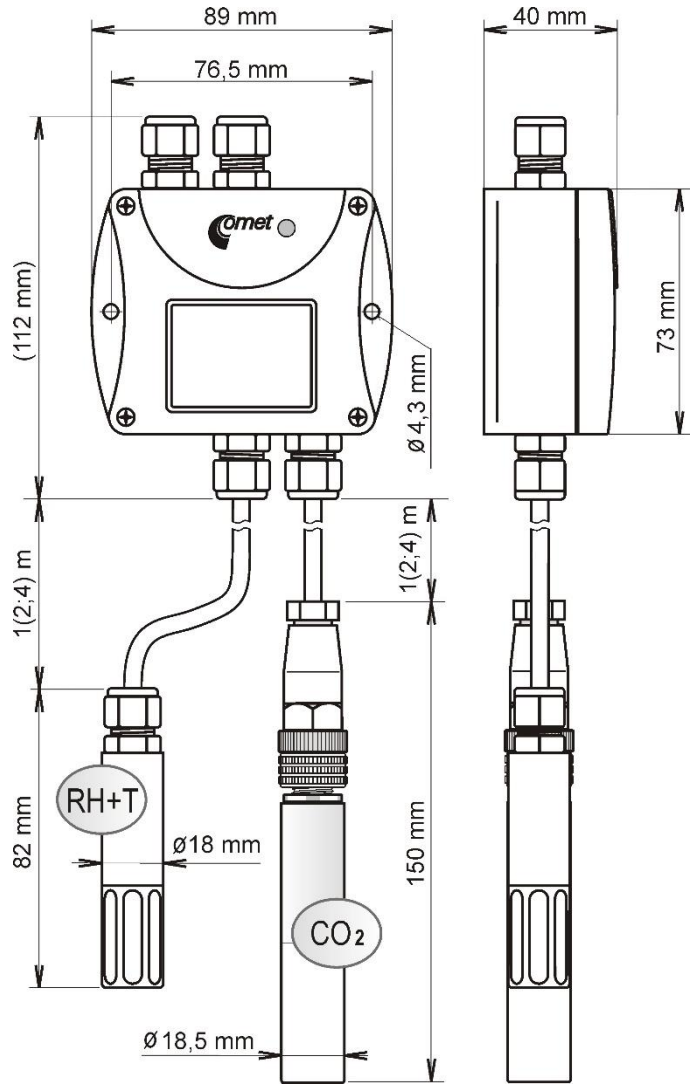

Typical application wiring, connection of terminals – RS232

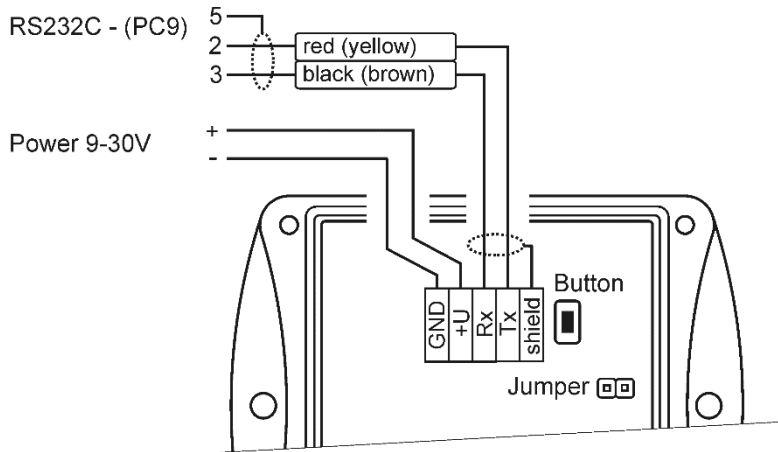

T6341L, T6441L

Connection:
see Appendix B

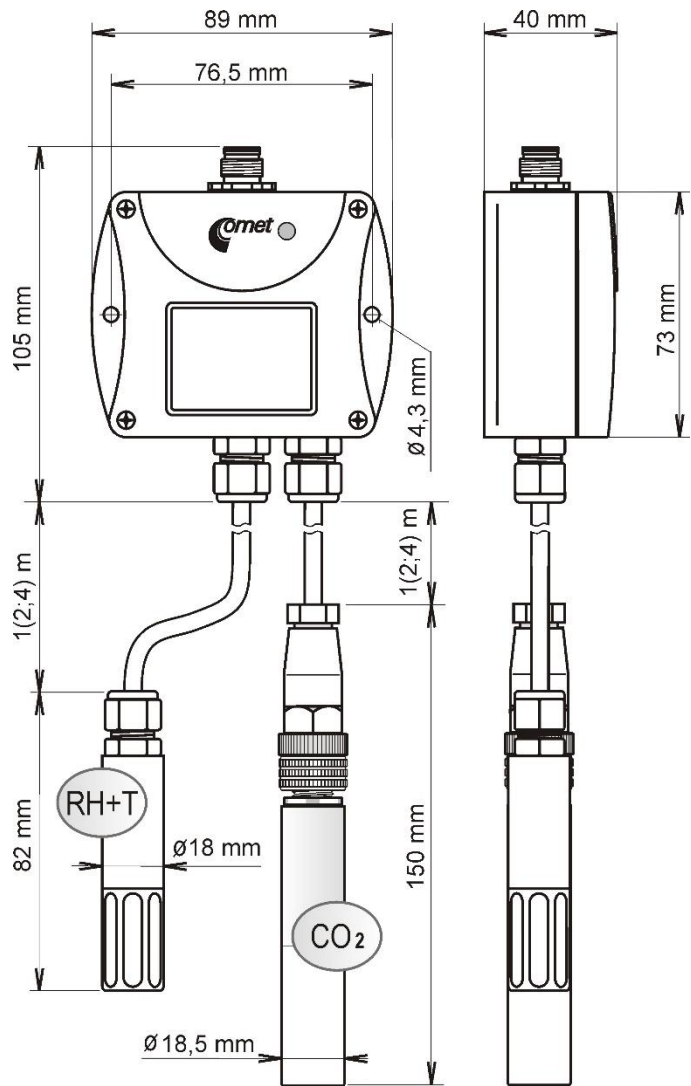

Typical application wiring, connection of terminals – RS485

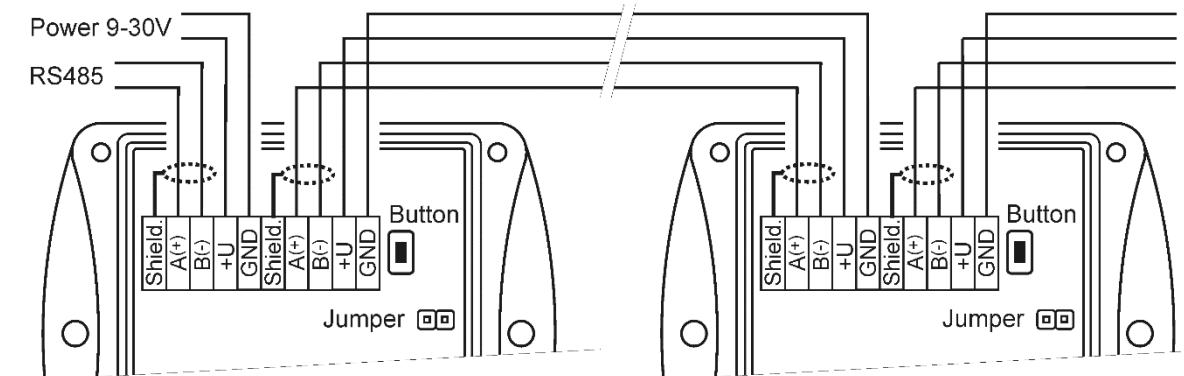

Info mode

If in doubt of setting of installed device, verification of its address is enabled even without using computer. Power should be connected. Devices with RS232 interface have address always set to one.

Unscrew device cover and shortly press button next to connection terminals (jumper should be opened). Actual adjusted address of the device is displayed on LCD display at decimal base, for HWg-Poseidon's communication protocol there is shown number corresponding with ASCII address code. Next press of button exits info mode and actual measured values are displayed.

Note: No measurement and communication is possible during info mode. If device stays in info mode for longer than 15 s, device automatically returns to measuring cycle.

Description of communication protocols

Detailed description of each communication protocols including examples of communication is available in individual document "*Description of communication protocols of Txxxx series*" which is free to download at www.cometsystem.com.

Note: After switching ON the power of the device it can last up to 2 s before the device starts to communicate and measure!

Modbus RTU

Control units communicate on master-slave principle in half-duplex operation. Only master can send request and only addressed device responds. During sending of request no other slave station should respond. During communication, data transfer proceeds in binary format. Each Byte is sent as eight bit data word in format: 1 start bit, data word 8 bit (LSB first), 2 stop bits¹, without parity. Device supports communication speed from 110Bd to 115200Bd.

Sent request and response have syntax: ADDRESS OF DEVICE – FUNCTION – Modbus CRC

Supported functions

03 (0x03): Reading of 16-bit registers (Read Holding Registers)

04 (0x04): Reading of 16-bit input gates (Read Input Registers)

16 (0x10): Setting of more 16-bit registers (Write Multiple Registers)

Jumper and button

Jumper and button are located next to connection terminals. If communication protocol Modbus is selected the function of jumper and button is as follows:

- Jumper opened – device memory is protected from writing, from device side it is only enabled to read measured value, writing to memory is disabled (no change of device address, communication speed and LCD setting is enabled).
- Jumper closed – writing to device memory is enabled by means of User's software.
- Jumper opened and button shortly pressed – device goes to Info mode, see chapter „*Info mode*”.

¹ Device sends two stop bits, for receive one stop bit is enough.

- Jumper closed and button pressed for longer than six seconds – causes restoring of manufacturer setting of communication protocol, i.e. sets Modbus RTU communication protocol, device address sets to 01h and communication speed to 9600Bd - after button press there is “dEF” message blinking at LCD display. Six seconds later message “dEF” stays shown, it means manufacturer setting of communication protocol is done.

Modbus registers of the device

Variable	Unit	Address[hex]^X	Address[dec]^X	Format	Size	Status
Measured temperature	[°C] [°F]*	0x0031	49	Int*10	BIN16	R
Measured relative humidity	[%]	0x0032	50	Int*10	BIN16	R
Computed value *	[*]	0x0033	51	Int*10	BIN16	R
Dew point temperature	[°C] [°F]*	0x0035	53	Int*10	BIN16	R
Absolute humidity	[g/m ³]	0x0036	54	Int*10	BIN16	R
Specific humidity	[g/kg]	0x0037	55	Int*10	BIN16	R
Mixing ratio	[g/kg]	0x0038	56	Int*10	BIN16	R
Specific enthalpy	[kJ/kg]	0x0039	57	Int*10	BIN16	R
CO ₂ concentration displayed on LCD	ppm	0x0034	52	Int	BIN16	R
CO ₂ concentration „FAST“ mode value	ppm	0x0054	84	Int	BIN16	R
CO ₂ concentration „SLOW“ mode value	ppm	0x0055	85	Int	BIN16	R
Address of device	[-]	0x2001	8193	Int	BIN16	R/W*
Code of communication speed	[-]	0x2002	8194	Int	BIN16	R/W*
Serial number of device Hi	[-]	0x1035	4149	BCD	BIN16	R
Serial number of device Lo	[-]	0x1036	4150	BCD	BIN16	R
Version of Firmware Hi	[-]	0x3001	12289	BCD	BIN16	R
Version of Firmware Lo	[-]	0x3002	12290	BCD	BIN16	R

Explanation:

- * depends on device setting (by User’s software)
- Int*10 register is in format integer*10
- R register is designed only for reading
- W* register is designed for writing, for details see file “*Description of communication protocols of Txxxx series*”
- X register addresses are indexed from zero – register 0x31 is physically sent as value 0x30, 0x32 as 0x31 (zero based addressing).

Note: In case there is a need for reading of measured values from the device with higher resolution than one decimal, measured values in device are stored also in „Float“ format, which is not directly compatible with IEEE754.

Protocol compatible with Advantech-ADAM standard

Control units communicate on master-slave principle in half-duplex operation. Only master can send requests and only addressed device responds. During sending request any of slave devices should respond. During communication data is transferred in ASCII format (in characters). Each Byte is sent as two ASCII characters. Device supports communication speed from 1200Bd to 115200Bd, parameters of communication link are 1 start bit + eight bit data word (LSB first) + 1 stop bit, without parity.

Jumper

Jumper is located next to connection terminals. If communication protocol compatible with standard Advantech-ADAM is selected, its function is the following:

- If jumper during switching ON the power is closed, device always communicates with following parameters regardless stored setting in the device: communication speed 9600 Bd, without check sum, device address 00
- If jumper during switching ON the power is not closed, device communicates in accordance with stored setting.
- If jumper is closed during device operation, device temporarily changes its address to 00, it will communicate in the same communication speed as before closing jumper and will communicate without check sum. After jumper is opened setting of address and check sum is reset in accordance with values stored in the device.
- Communication speed and check sum are possible to change only if jumper is closed.
- Jumper closed and button pressed for longer than six seconds – causes restoring of manufacturer setting of communication protocol, i.e. sets Modbus RTU communication protocol, device address sets to 01h and communication speed to 9600Bd - after button press there is “dEF” message blinking at LCD display. Six seconds later message “dEF” stays shown, it means manufacturer setting of communication protocol is done.

Command for value reading

- T5xxx transmitters of CO₂ concentration - command for reading of measured value is #AA(CRC) cr, where AA is device address, CRC is check sum (can be used or not)
- T6xxx transmitters of temperature, relative humidity and CO₂ concentration - command for reading of measured value is #AAx(CRC) cr, where AA is device address, x is number of communication channel, CRC is check sum (can be used or not)

<i>Measured value</i>	<i>Number of communication channel</i>
Temperature	0
Relative humidity	1
Computed value	2
CO ₂ concentration	3

Command #AA(CRC) cr for reading all measured values at once is supported for multi-channel devices since firmware version 02.60.

Response:

> (temperature)(relative humidity)(dew point temperature)(absolute humidity)
(specific humidity)(mixing ratio)(specific enthalpy)(CO₂ concentration)cr

ARION communication protocol - AMiT company

The device supports communication protocol ARiON version 1.00. For more details see file “Description of communication protocols of Txxxx series” or www.amit.cz. The reading of CO₂ concentration is not supported by this protocol.

Communication with HWg Poseidon units

Device supports communication with HWg-Poseidon units. For communication with this unit set the device with setup software TSensor to communication protocol HWg–Poseidon and set correct device address. This communication protocol supports read temperature at °C, relative humidity and one of computed value (dew point temperature or absolute humidity). The reading of CO₂ concentration is not supported by this protocol.

Jumper and button

If communication with HWg Poseidon unit is selected, the function of jumper and button is as follows:

- Jumper opened and button shortly pressed – device goes to Info mode, see chapter „Info mode”.
- Jumper closed and button pressed for longer than six seconds – causes restoring of manufacturer setting of communication protocol, i.e. sets Modbus RTU communication protocol, device address sets to 01 and communication speed to 9600Bd - after button press there is “dEF” message blinking at LCD display. Six seconds later message “dEF” stays shown, it means manufacturer setting of communication protocol is done.

Error States of the device

The device still make self-test. If error occurred, LCD show error code:

Error 0 - first line of LCD displays „Err0“. Check sum error of stored setting inside device’s memory. This error appears if incorrect writing procedure to device’s memory occurred or if damage of calibration data appeared. At this state device does not measure and calculate values. It is a serious error, contact distributor of the device to fix.

Error 1 - measured or calculated value (except concentration of CO₂) is over upper limit of allowed full scale range. This state appears in case of:

- Measured temperature is higher than approximately 600 °C (i.e. high non-measurable resistance of temperature sensor, probably opened circuit).
- Relative humidity is higher than 100%, i.e. damaged humidity sensor, or humidity calculation of humidity is not possible (due to error during temperature measurement).
- Computed value – calculation of the value is not possible (error during measurement of temperature or relative humidity or value is over range).

Error 2 - there is a reading „Err2“ on LCD display. Measured or calculated value is below lower limit of allowed full scale range or CO₂ concentration measurement error occurred. Value read from the device is -999.9. This state appears in case of:

- Measured temperature is lower than approximately -210°C (i.e. low resistance of temperature sensor, probably short circuit).
- Relative humidity is lower than 0%, i.e. damaged sensor for measurement of relative humidity, or calculation of humidity is not possible (due to error during temperature measurement).
- Computed value – calculation of computed value is not possible (error during measurement of temperature or relative humidity).

Error 3 - there is a reading „Err3“ on LCD display upper line. Error of internal A/D converter appeared (converter does not respond, probably damage of A/D converter). At this state device does not measure temperature and relative humidity. This error does not affect CO_2 concentration measurement. It is a serious error, contact distributor of the device.

Error 4 - there is a reading „Err4“ on LCD display. It is internal device error during initialization of CO_2 sensor. Under this condition device does not measure concentration of CO_2 . Value read from device is -9999. CO_2 sensor is probably damaged. It is a serious error, contact distributor of the device.

Readings on LCD display

$^{\circ}\text{C}$, $^{\circ}\text{F}$ - reading next to this symbol is measured temperature or error state of value.

%RH - reading next to this symbol is measured relative humidity or error state of value.

CO_2 ppm reading next to this symbol is measured concentration of CO_2 or error state of value.

$^{\circ}\text{C}$ / $^{\circ}\text{F}$ **DP** - reading next to this symbol is calculated dew point temperature or error state of value.

g/m^3 - reading next to this symbol is calculated absolute humidity or error state of value.

g/kg - reading next to this symbol is calculated specific humidity or mixing ratio (depends on device setting) or error state of value.

3 - this symbol is on if jumper is closed.

If specific enthalpy is selected, there is shown only value (number) without corresponding unit!

Technical parameters of the device:

RS 485 Interface:

Receiver-Input Resistance: 96 k Ω
Devices on bus: max. 256 (1/8 Unit Receiver Load)

Power:

9 to 30 V

Power consumption:

0.5 W during normal operation
max. 3 W for 50 ms with 15 s period

T5340, T5440 - CO₂ transmitter

Concentration of CO₂:

Accuracy: $\pm (50 \text{ ppm} + 2 \% \text{ of measuring value})$ at 25°C (77°F) and 1013 hPa
Range: 0 to 2000 ppm
Temp. dependence: typ. 2 ppm CO₂ / °C in the range 0 to 50 °C (32 to 122°F)
Long term stability: typ. 20 ppm / year
Resolution: 1 ppm

Response time:

t₉₀ < 195 s in „SLOW“ measurement mode
t₉₀ < 75 s in „FAST“ measurement mode

T5341, T5441 - CO₂ transmitter

Concentration of CO₂:

Accuracy: $\pm (100 \text{ ppm} + 5 \% \text{ of measuring value})$ at 25°C (77°F) and 1013 hPa
Range: 0 to 10 000 ppm
Temp. dependence: typ. 2 ppm CO₂ / °C in the range 0 to 50 °C (32 to 122°F)
Long term stability: typ. 20 ppm / year
Resolution: 1 ppm

Response time:

t₉₀ < 195 s in „SLOW“ measurement mode
t₉₀ < 75 s in „FAST“ measurement mode

T6340, T6440 - temperature, relative humidity and CO₂ transmitter

Temperature:

Accuracy: $\pm 0.4 \text{ }^\circ\text{C}$ ($\pm 0.7 \text{ }^\circ\text{F}$)
Range: -30 to +80 °C (-22 to 176 °F)
Resolution: 0.1 °C (0.2 °F)

Relative humidity:

Accuracy: $\pm 2.5 \% \text{RH}$ from 5 to 95 %RH at 23 °C (73,4 °F)
Range: 0 to 100 %RH, temperature compensated
Resolution: 0.1 %RH

Concentration of CO₂:

Accuracy: $\pm (50 \text{ ppm} + 2 \% \text{ of measuring value})$ at 25°C (77°F) and 1013 hPa
Range: 0 to 2000 ppm
Temp. dependence: typ. 2 ppm CO₂ / °C in the range 0 to 50 °C (32 to 122°F)
Long term stability: typ. 20 ppm / year
Resolution: 1 ppm

Measuring temperature and humidity range is limited in accordance with graph below!

Response time measurement of temperature and relative humidity with stainless steel mesh sensor cover (F5200B) and bronze sensor cover (F0000 - selectable option), air flow 1 m/s:
 temperature: $t_{90} < 6 \text{ min}$ (temperature step $20 \text{ }^\circ\text{C}$ ($36 \text{ }^\circ\text{F}$))
 relative humidity: $t_{90} < 30 \text{ s}$ (humidity step 65 \%RH , constant temperature)

Response time measurement of CO₂ concentration:

$t_{90} < 195 \text{ s}$ in „SLOW“ measurement mode
 $t_{90} < 75 \text{ s}$ in „FAST“ measurement mode

T6341, T6441 - temperature, relative humidity and CO₂ transmitter

Temperature:

Accuracy: $\pm 0.4 \text{ }^\circ\text{C}$ ($\pm 0.7 \text{ }^\circ\text{F}$)
 Range: $-30 \text{ to } +105 \text{ }^\circ\text{C}$ ($-22 \text{ to } 221 \text{ }^\circ\text{F}$)

Resolution: $0.1 \text{ }^\circ\text{C}$ ($0.2 \text{ }^\circ\text{F}$)

Relative humidity:

Accuracy: $\pm 2.5 \text{ \%RH}$ from $5 \text{ to } 95 \text{ \%RH}$ at $23 \text{ }^\circ\text{C}$ ($73.4 \text{ }^\circ\text{F}$)

Range: $0 \text{ to } 100 \text{ \%RH}$, temperature compensated

Resolution: 0.1 \%RH

Concentration of CO₂:

Accuracy: $\pm (100 \text{ ppm} + 5 \text{ \% of measuring value})$ at 25°C (77°F) and 1013 hPa

Range: $0 \text{ to } 10\,000 \text{ ppm}$

Temp. dependence: $\text{typ. } 2 \text{ ppm CO}_2 / \text{ }^\circ\text{C}$ in the range $0 \text{ to } 50 \text{ }^\circ\text{C}$ ($32 \text{ to } 122^\circ\text{F}$)

Long term stability: $\text{typ. } 20 \text{ ppm / year}$

Resolution: 1 ppm

Measuring temperature and humidity range is limited in accordance with graph below!

Response time measurement of temperature and relative humidity with stainless steel mesh sensor cover (F5200B) and bronze sensor cover (F0000 - selectable option), air flow 1 m/s:

temperature: $t_{90} < 6 \text{ min}$ (temperature step $20 \text{ }^\circ\text{C}$ ($36 \text{ }^\circ\text{F}$))

relative humidity: $t_{90} < 30 \text{ s}$ (humidity step 65 \%RH , constant temperature)

Response time measurement of CO₂ concentration:

$t_{90} < 195 \text{ s}$ in „SLOW“ measurement mode

$t_{90} < 75 \text{ s}$ in „FAST“ measurement mode

Relative humidity and temperature restriction

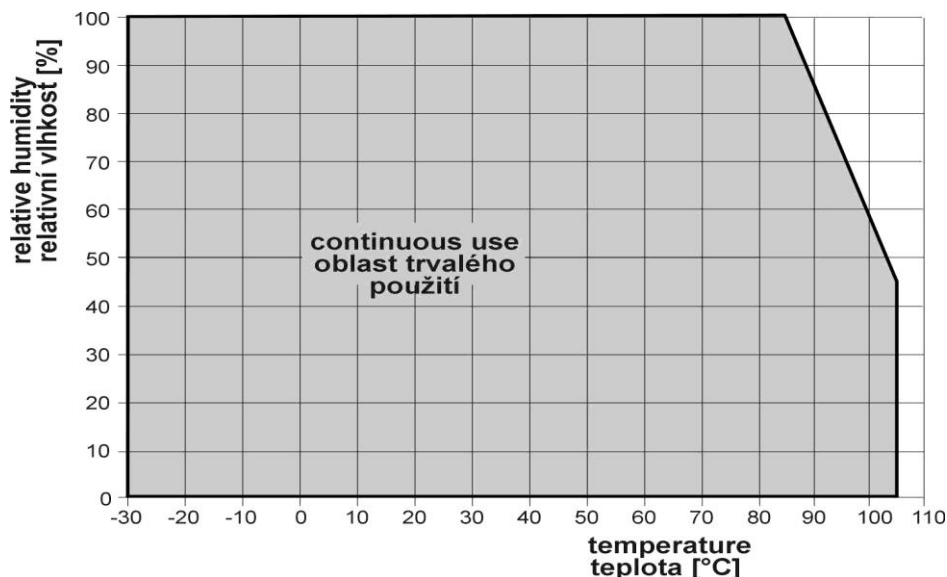

The value computed from ambient temperature and relative humidity:

Dew point temperature

Accuracy: $\pm 1.5\text{ }^{\circ}\text{C}$ ($\pm 2.7\text{ }^{\circ}\text{F}$) at ambient temperature $T < 25\text{ }^{\circ}\text{C}$ ($77\text{ }^{\circ}\text{F}$) and $\text{RV} > 30\%$,
for more details see graphs below

Range: $-60\text{ to }+80\text{ }^{\circ}\text{C}$ ($-22\text{ to }176\text{ }^{\circ}\text{F}$)

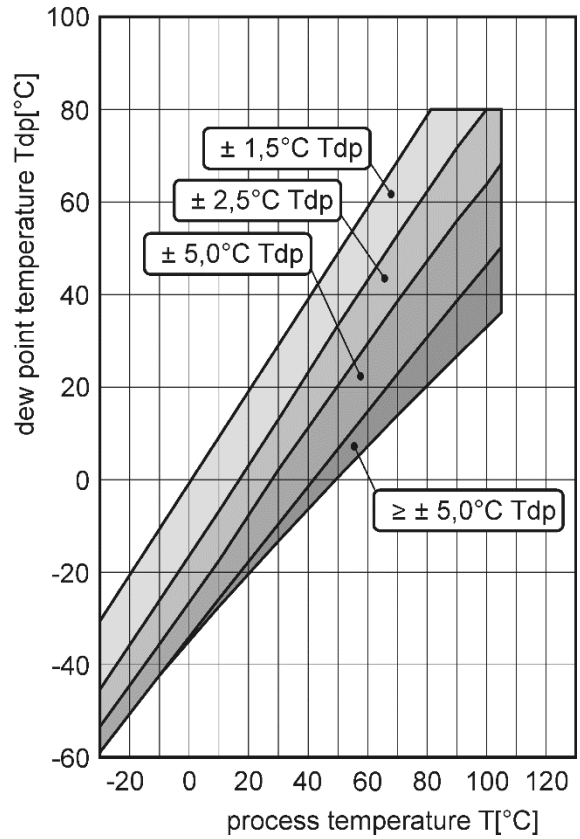
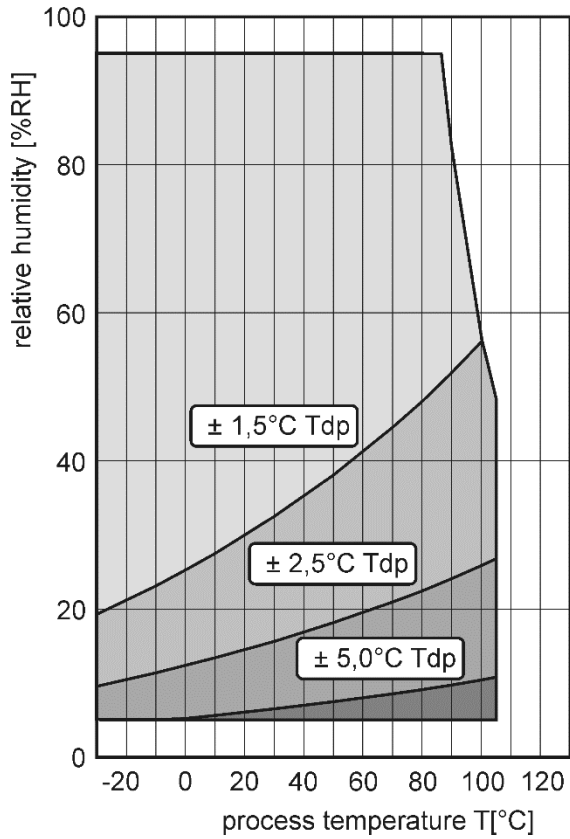

Absolute humidity

Accuracy: $\pm 3\text{ g/m}^3$ at ambient temperature $T < 40\text{ }^{\circ}\text{C}$ ($104\text{ }^{\circ}\text{F}$), for more details see graph

Range: $0\text{ to }400\text{ g/m}^3$

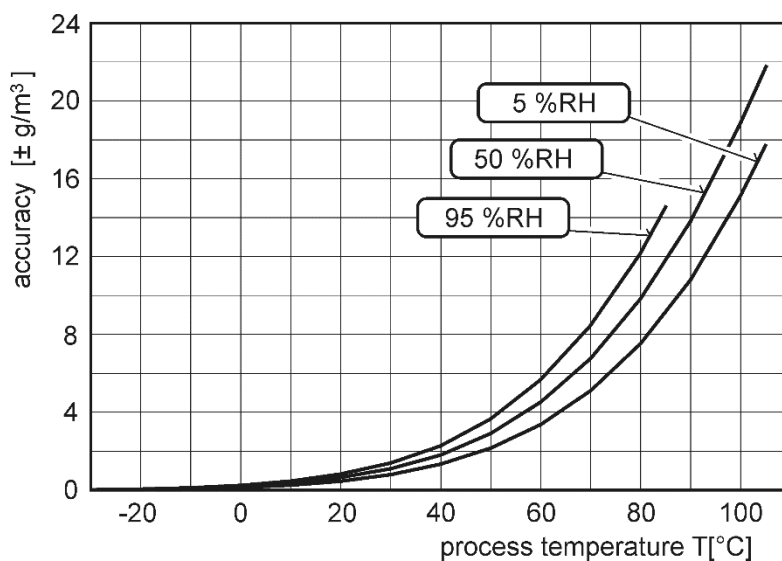

Specific humidity²

Accuracy: ± 2.1 g/kg at ambient temperature $T < 35^{\circ}\text{C}$ (95°F)

Range: 0 to 550 g/kg

Mixing ratio²

Accuracy: ± 2.2 g/kg at ambient temperature $T < 35^{\circ}\text{C}$ (95°F)

Range: 0 to 995 g/kg

Specific enthalpy²

Accuracy: ± 4 kJ/kg at ambient temperature $T < 25^{\circ}\text{C}$ (77°F)

Range: 0 to 995 kJ/kg³

The values computed from ambient temperature and relative humidity including their accuracy you can exactly determine by the program **Conversions**. It is free to download at <http://www.cometsystem.com>.

Operating conditions

Operating temperature range:

electronics T5340(L), T5440(L), T6340(L), T6440(L): -30 to $+60^{\circ}\text{C}$ (-22 to $+140^{\circ}\text{F}$)

electronics T5341(L), T5441(L), T6341(L), T6441(L): -30 to $+80^{\circ}\text{C}$ (-22 to $+176^{\circ}\text{F}$)

measuring end of stem T6340(L), T6440(L): -30 to $+80^{\circ}\text{C}$ (-22 to $+176^{\circ}\text{F}$)

CO2 probe T5341(L), T5441(L), T6341(L), T6441(L): -40 to $+60^{\circ}\text{C}$ (-40 to $+140^{\circ}\text{F}$)

RH+T probe T6341(L), T6441(L): -30 to $+105^{\circ}\text{C}$ (-22 to $+221^{\circ}\text{F}$)

It is recommended to switch off the LCD display at ambient temperatures above 70°C .

Operating humidity range:

T5340(L), T5440(L), T6340(L), T6440(L): 5 to 95 % RH (no condensation)

T5341(L), T5441(L), T6341(L), T6441(L): 0 to 100 % RH (no condensation)

Operating barometric pressure range: 850 to 1100 hPa

Recommended calibration interval :

temperature T6340(L), T6440(L), T6341(L), T6441(L): 2 years

relative humidity T6340(L), T6440(L), T6341(L), T6441(L): 1 years

CO2 concentration: 5 years

Protection:

electronics T5340(L), T5440(L), T6340(L), T6440(L): IP30

electronics T5341(L), T5441(L), T6341(L), T6441(L): IP65

measuring end of stem T6340(L), T6440(L): IP40

CO2 probe T5341(L), T5441(L), T6341(L), T6441(L): IP65

RH+T probe T6341(L), T6441(L): IP40

Working position:

T5340(L), T5440(L) with cable glands (connector) upwards

T5341(L), T5441(L), T6341(L), T6441(L) any position

T6340(L), T6440(L) with sensor cover downwards. When mounting the transmitter to 19" rack with universal holder MP046 (optional accessory) then sensor cover can be placed horizontally.

² This value depends on the atmospheric pressure. For computing is used constant value stored in device memory. Default value preset by manufacturer is 1013hPa and can be changed by user's software.

³ This maximum is reached under conditions about $70^{\circ}\text{C}/100\%\text{RH}$ or $80^{\circ}\text{C}/70\%\text{RH}$

EMC: EN 61326-1, EN 55011

Not allowed manipulations: It is not allowed to operate the device under conditions other than specified in technical parameters. Devices are not designed for locations with chemically aggressive environment. Temperature and humidity sensors must not be exposed to direct contact with water or other liquids. It is not allowed to remove the sensor cover to avoid any mechanical damage of the sensors.

Storage conditions:

temperature: -40 to +60 °C (-40 to 140 °F)
relative humidity: 5 to 95 % RH (no condensation)
atmospheric pressure: 700 až 1100 hPa

Mechanical dimensions: see dimensional drawings

Weight: approximately

T5340(L), T5440(L) 150 g
T6340(L), T6440(L) 160 g
T5341(L), T5441(L) / 1m sonda 250 g
T5341(L), T5441(L) / 2m sonda 280 g
T5341(L), T5441(L) / 4m sonda 340 g
T6341(L), T6441(L) / 1m sondy 330 g
T6341(L), T6441(L) / 2m sondy 400 g
T6341(L), T6441(L) / 4m sondy 540 g

Weight of devices with RS232 output (transmitters Tx3xx) is given without communication cable (weight of the cable is 70g).

Material of the case: ABS

End of operation

Device itself (after its life) is necessary to liquidate ecologically!

Technical support and service

Technical support and service is provided by distributor. For contact see warranty certificate. You can use discussion forum at web address: <http://www.forum.cometsystem.cz/>.

Appendix A

Connection of transmitters with RS485 output to the PC

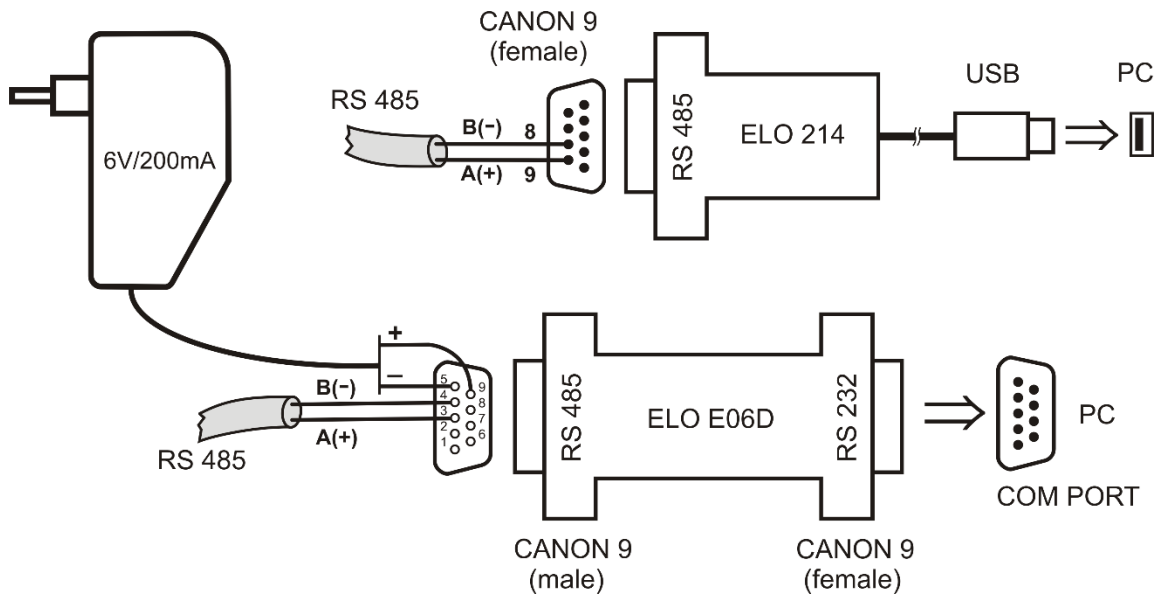

The **ELO E214** converter is an optional accessory for connection of transmitter with RS485 interface to the PC via USB port. Link RS485 is connected across pin 9 A(+) and pin 8 B(-). The pull up, pull down and termination resistors are part of the transmitter. These internal resistors can be connected to the bus by connecting the corresponding pins of CANON connector (for more information see the operation manual for ELO E214).

The **ELO E06D** converter is an optional accessory for connection of transmitter with RS485 interface to the PC via serial port RS232. Connector marked RS232 connect directly to the PC. Power voltage +6V DC from an external acdc adapter connect to pin 9 of connector marked RS485, 0V connect to pin 5 and link RS485 connect across pin 3 A(+) and pin 4 B(-). Time out setting is performed by connecting the corresponding pins of connector marked RS485 (for more information see the operation manual for ELO E06D).

Appendix B

Connection of TxxxxL transmitters

